

FAMILY OWNED AND OPERATED SINCE 1933



Hannay Reels®
The reel leader.

Petroleum Hose Reels



The
Hannay
Way

Home Fuel Delivery • In-plant Refueling • Marine Refueling
Off-road Vehicle/Equipment Refueling

www.hannay.com

Pride in workmanship • Reels built to order • Consistent quality • Service with integrity • Value for your dollar

Note to Designers and Engineers:

The reels shown in this catalog are the standard of the industry.

These models reflect various installation and performance requirements.

The high quality of our standard steel construction is only the beginning.

Hannay Reels offers any size configuration to fit a defined space, and we construct many models of reels of aluminum or stainless steel. Specifically, we use 5000 and 6000

Series aluminum and 304 stainless steel in the manufacture of frames, discs, drums and internals as well as other structural components. This type of construction eliminates the need for maintenance repainting and part replacement due to rust or corrosion.

Please consult factory on any fuel handling questions.

For the many accessories and components available on our standard reel models such as roller guides, switches, brakes and locks, etc., please refer to our Ordering & Accessory Guide H-0415-OA.

Paint Notice

To meet the requirements and performance of vehicle and OEM apparatus paints we recommend our reels be painted with the same or equal paint as used on the specific apparatus the reel is being mounted on.

Hannay Reels will supply any model or custom reel or part with an automotive primer or rust preventative oil finish upon request, allowing application of final coating at your facility. Or at additional cost Hannay can prime / pre-paint all material before final assembly.

In today's regulatory environment this would be the most cost-effective way to meet your finishing standards.

Consult factory for other optional finishes

Standard finish is oven cured enamel. High performance finishes for demanding and corrosive environments are available at an additional cost. Consult factory for specific requirements.

S E R I E S

1 1/2"

MANUAL OR POWER REWIND REELS

To handle single 1" through 1-1/2" I.D. hose.

- A strong, heavy-duty reel.
- Gear-driven crank rewind or chain and sprocket drive powered by an electric, hydraulic or compressed air motor.
- Optional auxiliary crank rewind for power rewind reels.
- Choose EP or EPJ option.
- Comet brake, standard on power rewind without auxiliary crank.
- 90° ball bearing swivel joint with 1-1/2" female NPT threads and 2" victaulic groove.
- Flanged riser with 1-1/2" female NPT threads.
- Other sizes and/or threads can be furnished and must be specified.
- Inlet, outlet riser, hub assembly are steel.
- Stainless steel, aluminum, at extra cost.
- Rollers may be purchased, specify roller position.
- Mounting brackets are necessary.
- Pressures to 600 psi (41 bar)
- Temperatures from -40°F to +175°F (-40° C to +79° C).
- Consult factory for other pressures & temps.

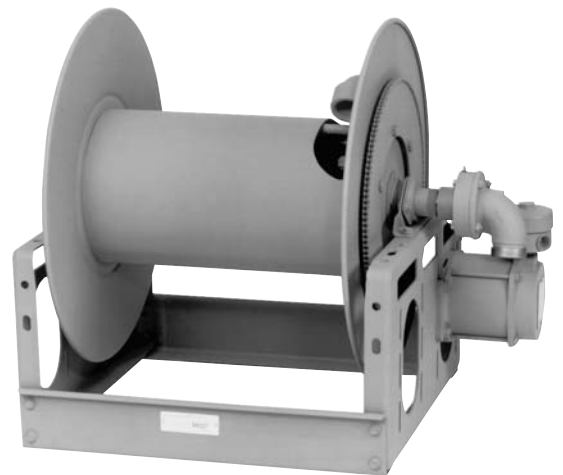

Series 1-1/2"

1 1/2"

Model Number	Hose Capacity of Reel feet m.				Approx. Weight Crank Rewind lb. kg. See Note 4		Reel Dimensions inches mm.										
	I.D. (in) I.D. (mm)	1" 25	1-1/4" 32	1-3/8" 35	1-1/2" 38	NET	SHIP	A	B	D	E	F crank	F power	G	H	X	Y
	O.D. (in) O.D. (mm)	1.58" 40	1.89" 48	2" 51	2.06" 52												
26-19-21		70 21	60 18	50 15	50 15	99 45	141 64	23 584	17.5 445	20.5 521	18.75 476	29.5 749	31.88 810	21.5 546	12.12 308	15 381	16.75 425
32-19-21		100 30	90 27	85 26	75 23	112 51	154 70	29.5 749	24 610	20.5 521	18.75 476	36.0 914	38.38 975	21.5 546	12.12 308	21.5 546	16.75 425
40-19-21		125 38	100 30	100 30	100 30	128 58	170 77	37.5 953	32 813	20.5 521	18.75 476	44.0 1118	46.38 1178	21.5 546	12.12 308	29.5 749	16.75 425
24-23-24		100 30	90 27	80 24	50 15	102 46	144 65	21 533	15.5 394	20.5 521	22.75 578	27.5 699	29.88 759	23.5 597	12.12 308	13 330	16.75 425
32-23-24		150 46	150 46	125 38	75 23	119 54	161 73	29.5 749	24 610	20.5 521	22.75 578	36.0 914	38.38 975	23.5 597	12.12 308	21.5 546	16.75 425
38-23-24		200 61	190 58	170 52	100 30	130 59	172 78	35 889	29.5 749	20.5 521	22.75 578	41.5 1054	43.88 1115	23.5 597	12.12 308	27 686	16.75 425
20-25-26		110 34	70 21	60 18	50 15	106 48	148 67	17 432	11.5 292	25.5 648	24.75 629	23.5 597	25.88 657	27.88 708	15.5 394	9 229	21.75 552
24-25-26		140 43	95 29	85 26	75 23	114 52	156 71	21 533	15.5 394	25.5 648	24.75 629	27.5 699	29.88 759	27.88 708	15.5 394	13 330	21.75 552
28-25-26		200 61	130 40	120 37	100 30	123 56	165 75	25.5 648	20.0 508	25.5 648	24.75 629	32.0 813	34.38 873	27.88 708	15.5 394	17.5 445	21.75 552
16-30-31		90 27	50 15	50 15	50 15	106 48	156 71	13 330	7.5 191	25.5 648	28.75 730	19.5 495	21.88 556	29.88 759	15.5 394	7.75 197	21.75 552
20-30-31		155 47	140 43	80 24	75 23	114 52	164 74	17 432	11.5 292	25.5 648	28.75 730	23.5 597	25.88 657	29.88 759	15.5 394	9 229	21.75 552
*22-30-31		185 56	160 49	100 30	100 30	118 54	168 76	19 483	13.5 343	25.5 648	28.75 730	25.5 648	27.88 708	29.88 759	15.5 394	11 279	21.75 552
*28-30-31		275 84	250 76	175 53	150 46	131 59	181 82	25.5 648	20.0 508	25.5 648	28.75 730	32.0 813	34.38 873	29.88 759	15.5 394	17.5 445	21.75 552
*24-33-34		275 84	190 58	175 53	175 53	129 59	179 81	20.5 521	15.5 394	31.5 800	31.75 806	27.25 692	29.63 753	33.62 854	17.75 451	13 330	27.75 705

Notes:

- Specifications subject to change.
- Upon request, reels can be supplied with drum lengths other than shown and with disc sizes in other diameters.
- Dimensions shown for reels up to and including 30-31 disc size reflect pressed frames. All others are channel frames.
- Weights shown in chart are for crank rewind models. ADD these amounts for power rewind models:

	Net (lbs.)	Ship (lbs.)	Net (kg.)	Ship (kg.)
Electric	40	40	18.1	18.1
Hydraulic	20	20	9.1	9.1
Air	20	20	9.1	9.1

- When ordering power rewind models, prefix model number with:
 - A = Air Rewind—Supplied with control valve and hose.
 - EP = Electric Rewind (1/2HP)—12v and 24v DC rewind supplied with non-explosion proof switch and solenoid, 115v AC rewind is not supplied with switch but it can be ordered separately.
 - EPJ = Explosion Proof Electric Rewind (1/2 HP)—Supplied with explosion proof switch, solenoid, and junction box.
 - HD = Hydraulic Rewind—Not supplied with control valve.
- For a detailed parts breakdown drawing, request ISO 18.
- For Air Rewind on models over 100 ft. of 1-1/2" consult factory.

8. Be sure to check dimensions and weights prior to ordering.

NOTICE: A Flexible Connector must be used between the inlet pipe and the inlet swivel joint.

* Some applications may require a different motor and/or a clutch/reduction unit.

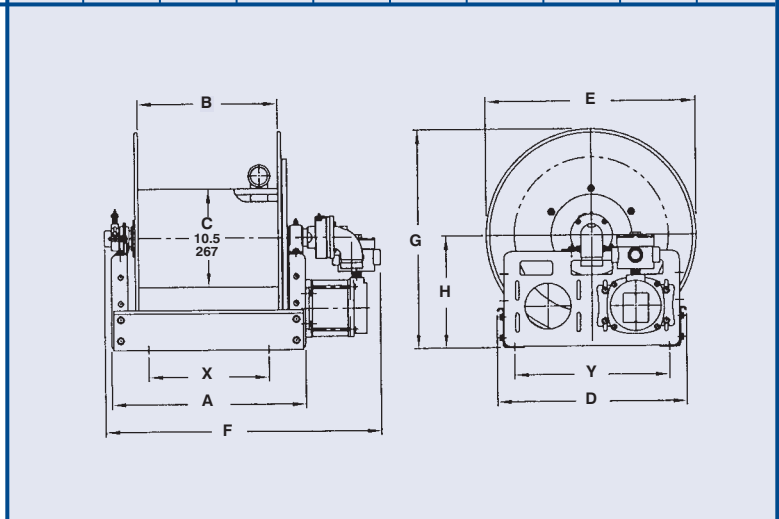

2"

MANUAL OR POWER REWIND REELS

To handle single 1-1/2" or 2" I.D. hose.

- Gear-driven crank rewind or chain and sprocket drive powered by an electric, hydraulic or compressed air motor.
- Optional auxiliary crank rewind for power rewind reels.
- Choose EP or EPJ option.
- Comet brake on power rewind without auxiliary crank.
- 90° ball bearing swivel joint with 2" victaulic.
- Flanged riser with 2" female NPT threads.
- Other sizes and/or threads can be furnished and must be specified.
- Inlet, riser, hub assembly are steel.
- Stainless steel, aluminum at extra cost.
- Rollers may be purchased, specify roller position.
- Mounting brackets are necessary.
- Pressures to 600 psi (41 bar).
- Temperatures from -40° F to +175° F (-40° C to +79° C).
- Consult factory for other pressures & temps.

- Recommended on reels with 39" diameter or larger discs, increased torque, slower rewind speeds.
- Factory-installed.



**Series 2"
EPJ Option Shown**

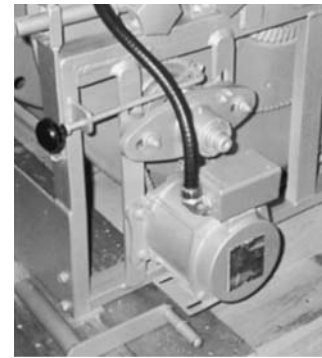

Chain Clutch - Reduction Units

Model Number	Hose Capacity of Reel feet m.			Approx. Weight Crank Rewind lb. kg. See Notes 3		Reel Dimensions inches mm.									
	I.D. (in) I.D. (mm)	1 1/2" 38	2" 51	NET	SHIP	A	B	D	E	F crank	F power	G	H	X	Y
	O.D. (in) O.D. (mm)	2.06" 52	2.67" 68												
232-26-27		70 21	50 15	104 47	154 70	23.75 603	17.5 445	27 686	25.75 654	31 787	31.63 803	26.62 676	13.75 349	16.25 413	23.25 591
238-26-27		100 30	75 23	145 66	195 88	30.25 768	24 610	27 686	25.75 654	37.5 953	38.13 969	26.62 676	13.75 349	22.75 578	23.25 591
246-26-27		140 43	100 30	196 89	246 112	38.25 972	32 813	27 686	25.75 654	45.5 1156	46.13 1172	26.62 676	13.75 349	30.75 781	23.25 591
224-33-34		60 18	50 15	70 32	140 64	15.75 400	9.5 241	31.5 800	31.75 806	23 584	23.63 600	33.38 848	17.5 445	8.25 210	27.75 705
228-33-34		100 30	75 23	92 42	162 73	19.75 502	13.5 343	31.5 800	31.75 806	27 686	27.63 702848	33.38 445	17.5 311	12.25 705	27.75 705
234-33-34		140 43	100 30	133 60	203 92	26.25 667	20 508	31.5 800	31.75 806	33.5 851	34.13 867	33.38 848	17.5 445	18.75 476	27.75 705
232-39-40		250 76	150 46	180 82	250 113	23.75 603	17.5 445	40 1016	39 991	31 787	33 838	39.88 1013	20.38 518	16.25 413	37 940
240-39-40		350 107	200 61	218 99	288 131	32.25 819	26 660	40 1016	39 991	39.5 1003	41.5 1054	39.88 1013	20.38 518	22.75 578	37 940

Notes:

- Specifications subject to change.
- Upon request, reels can be supplied with drum lengths other than shown and with disc sizes in other diameters.
- Weights shown in chart are for crank rewind models. ADD these amounts for power rewind models:

	Net (lbs.)	Ship (lbs.)	Net (kg.)	Ship (kg.)
Electric	40	40	18.1	18.1
Hydraulic	20	20	9.1	9.1
Air	20	20	9.1	9.1

- When ordering power rewind models, prefix model number with:
 A = Air Rewind—Supplied with control valve and hose.
 EP = Electric Rewind (1/2HP)—12v and 24v DC rewind supplied with non-explosion proof switch and solenoid, 115v AC rewind is not supplied with switch but it can be ordered separately.
 EPJ = Explosion Proof Electric Rewind (1/2 HP)—Supplied with explosion proof switch, solenoid, and junction box.
 HD = Hydraulic Rewind—Not supplied with control valve.

5. For a detailed parts breakdown drawing, request ISO 35.

6. Be sure to check dimensions and weights prior to ordering.

NOTICE: A Flexible Connector must be used between the inlet pipe and the inlet swivel joint.

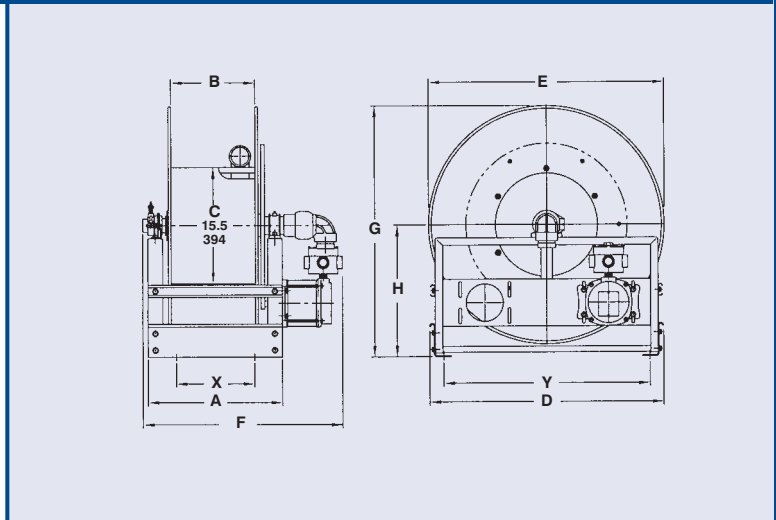

IV

POWER REWIND REELS FOR INVERTED INSTALLATION

To handle single 1-1/4" I.D. through 2" I.D. hose.

- Chain and sprocket drive powered by an electric, hydraulic, or compressed air motor.
- Comet brake, air caliper brake, standard.
- 90° ball bearing swivel joint with 1-1/2" female NPT and 2" groove.
- Optional 2" intervals also available.
- Flanged riser with 1-1/2" female NPT threads.
- Inlet, riser, hub assembly are steel.
- Stainless steel, aluminum, at extra cost.
- Pressures to 600 psi (41 bar).
- Temperatures from -40° F to +175° F (-40° C to +79° C).
- Consult factory for other pressures & temps.



Standard Configuration Shown

Model Number	Hose Capacity of Reel				Approx. Weight		Reel Dimensions										
	feet				lb.		inches										
	m.				kg.		mm.										
For Power Rewind See Note 3	I.D. (in)	1 1/4"	1 3/8"	1 1/2"	2"	NET	SHIP	A	B	C	D	E	F	G	H	X	Y
	I.D. (mm)	32	35	38	51												
IV 24-33-34		180	170	170	—	175	200	22.25	15.5	10.5	32.37	41	29.5	33.88	18	20.25	24.25
		55	52	52	—	79	91	565	394	267	822	1041	749	861	457	514	616
IV 22-35-36		210	145	145	—	190	220	20.25	13.5	10.5	32.37	41.75	27.5	34.88	18	18.25	24.25
		64	44	44	—	86	100	514	343	267	822	1060	699	886	457	464	616
IV 18-39-40*		185	115	115	70	260	280	16.25	9.5	15.5	34.25	45.5	23.5	40.75	21.25	14.25	27
		56	35	35	21	118	127	413	241	394	870	1156	597	1035	540	362	686
IV 20-39-40*		225	150	150	95	270	290	18.25	11.5	15.5	34.25	45.5	25.5	40.75	21.25	18.25	27
		69	46	46	29	122	132	464	292	394	870	1156	648	1035	540	464	686
IV 16-45-46*		175	140	140	60	280	300	14.25	7.5	15.5	39	51	21.5	46.25	23.75	12.23	31.38
		53	43	43	18	127	136	362	191	394	991	1295	546	1175	603	311	797
IV 18-45-46*		250	190	190	95	290	310	16.25	9.5	15.5	39	51	23.5	46.25	23.75	14.25	31.38
		76	58	58	29	132	141	413	241	394	991	1295	597	1175	603	362	797

Notes:

1. Specifications subject to change.
2. Upon request, reels can be supplied with drum lengths other than shown and with disc sizes in other diameters.
3. When ordering power rewind models, prefix model number with:
 A = Air Rewind—Supplied with control valve and hose.
 EP = Electric Rewind (2/3HP)—12v and 24v DC rewind supplied with non-explosion proof switch and solenoid.
 EPJ = Explosion Proof Electric Rewind (2/3 HP)—Supplied with explosion proof switch, solenoid, and junction box.
 HD = Hydraulic Rewind—Not supplied with control valve.
4. For a detailed parts breakdown drawing, request ISO 103.
5. Be sure to check dimensions and weights prior to ordering.

NOTICE: A Flexible Connector must be used between the inlet pipe and the inlet swivel joint.

* When ordering with 2" inlet/outlet, place a "2" after IV.
 re: IV 220-39-40

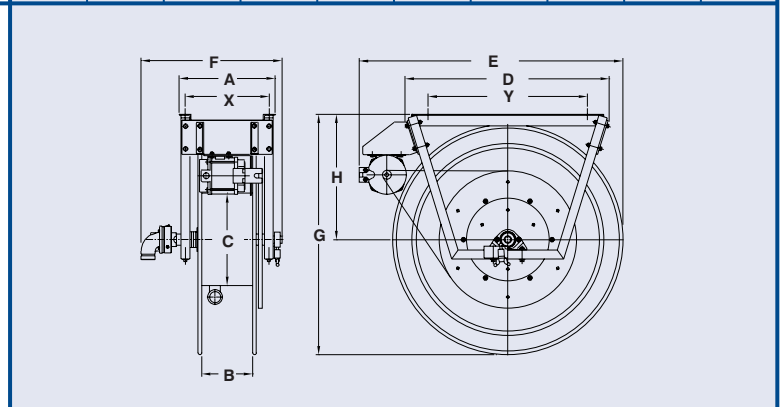

IV 5000

SINGLE WRAP POWER REWIND REELS



Standard Model Shown
(Hose not included)

To handle single 1-1/2" I.D. through 2" I.D. hose.

- Effortless and fast rewinding, wrapping, guiding of hose.
- Chain and sprocket drive powered by electric, hydraulic, compressed air motor.
- Auxiliary crank rewind.
- 12 volt rewind, comet brake standard.
- Air brake optional.
- 5100 series - 90° ball bearing swivel joint 1-1/2" female NPT threads, 2" victaulic groove, flanged riser with 1-1/2" female NPT threads.
- 5200 series - 90° ball bearing swivel joint 2" victaulic groove, flanged riser with 2" female NPT threads.
- Inlet, hub assembly is aluminum.
- Joint & riser ductile iron for petroleum fuel.
- Pressures to 600 psi (41 bar).
- Temperatures from -40° F to +175° F (-40° C to +79° C).
- Standard with a reduction unit only. Electric clutch units optional.
- Consult factory for other pressures & temps.

Model Number	Hose Capacity of Reel feet				Approx. Weight		Reel Dimensions							
	m.				lb.	kg.	inches							
	I.D. (in) I.D. (mm)	1 3/8" 35	1 1/2" 38	2" 51	NET	SHIP	A	B	C	D	E	F Power	G	H
For Power Rewind See Note 2	O.D. (in) O.D. (mm)	2.00 51	2.06 52	2.67 68										
5111-48-50-20	— —	50 15	— —	310 141	385 175	11 279	2.75 70	20 508	40 1016	48 1219	17.5 445	50 1270	26 660	
5111-56-58-20	— —	75 23	— —	330 150	405 184	11 279	2.75 70	20 508	40 1016	56 1422	17.5 445	58 1473	30 762	
5111-62-64-20	100 30	100 30	— —	340 154	415 188	11 279	2.75 70	20 508	40 1016	62 1575	17.5 445	64 1626	33 838	
5111-72-74-20	150 46	— —	— —	350 159	425 193	11 279	2.75 70	20 508	40 1016	72 1829	17.5 445	74 1880	38 965	
5218-56-58-24	— —	— —	50 15	370 168	445 202	12 305	3.75 95	24 610	40 1016	56 1422	19.25 489	58 1473	30 762	
5218-62-64-24	— —	— —	75 23	390 177	465 211	12 305	3.75 95	24 610	40 1016	62 1575	19.25 489	64 1626	33 838	
5218-70-72-24	— —	— —	100 30	400 181	475 215	12 305	3.75 95	24 610	40 1016	70 1778	19.25 489	72 1829	37 940	

Notes:

1. Specifications subject to change.
2. When ordering power rewind models, prefix model number with:
A = Air Rewind EP = Electric Rewind (1/2 HP) HD = Hydraulic Rewind
(Air rewind reels are supplied with control valve and hose;
12v and 24v DC rewind reels are supplied with switch and solenoid;
hydraulic rewind reels are not supplied with control valve.)
3. For a detailed parts breakdown drawing, request ISO 197.
4. **Be sure to check dimensions and weights prior to ordering.**

NOTICE: A Flexible Connector must be used between the inlet pipe and the inlet swivel joint.

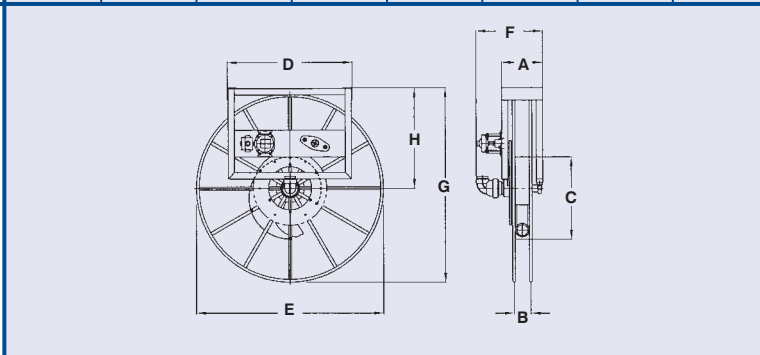

Guide for Series IV Inverted Installations

For reels with 1-1/2" I.D. hub assembly to handle 1-1/4" through 2" I.D. hose.

When ordering a reel for inverted installation, please specify which of the following component locations you prefer. Please specify component location by letter. If not otherwise specified, reels will be shipped as shown in A.

FROM CURBSIDE

FROM STREETSIDE

Installation A

Hose unwinds from top of reel to curbside and from bottom of reel to street-side. Swivel joint is on side nearest tank. Rewind mechanism and braking devices are at the rear of the truck. Rewind motor is on streetside.

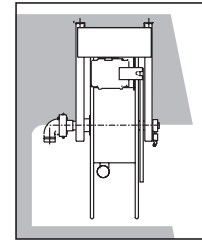
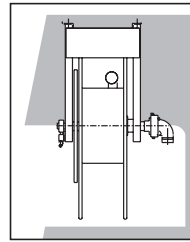

Installation B

Hose unwinds from top of reel to curbside and from bottom of reel to street-side. Swivel joint, rewind mechanism, braking and locking devices are at the rear of the truck. Rewind motor is on streetside.

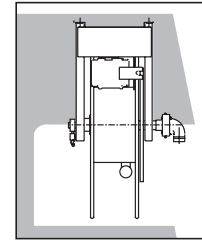
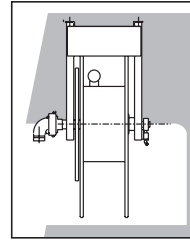

Installation C

Hose unwinds from bottom of reel to curbside and from top of reel to street-side. Swivel joint is on side nearest tank. Rewind mechanism, braking and locking devices are at the rear of the truck. Rewind motor is on streetside.

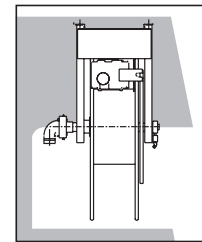
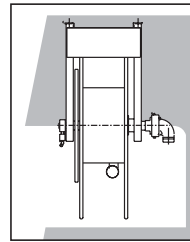

Family owned and operated since 1933, Hannay Reels is a leader in both OEM and aftermarket applications. Hannay offers thousands of standard hose reel and cable reel models, as well as unmatched custom capabilities. We can easily and affordably customize a reel to meet your exact specifications – built to last, delivered fast. Additional catalogs are available through your local Hannay Reels dealer or online at www.hannay.com.



553 State Route 143 • Westerlo, New York 12193-0159
Toll Free Phone: 1-877-GO-REELS • Toll Free Fax: 1-800-REELING

E-mail: reels@hannay.com

Intl. Phone: 1-518-797-3791 • Intl. Fax: 1-518-797-3259

www.hannay.com



MADE IN U.S.A.